

# STINGER



Fast, Easy  
& Portable



## **AES Raptor Stinger™ Mobile Fall Protection Unit**

The Stinger Mobile Fall anchor is a compact and transportable unit that lends itself to the struggles a worker faces on today's jobsites. The Stinger can easily be loaded into the back of a pickup, and will fit into elevators and through doorways. With its unique design the weights can be removed easily reducing the overall weight of the main unit, allowing workers to take the Stinger up stairs and through penthouses.

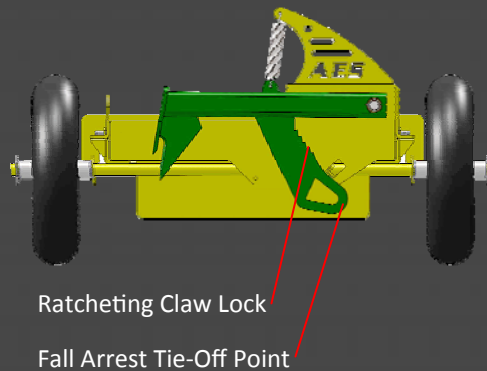
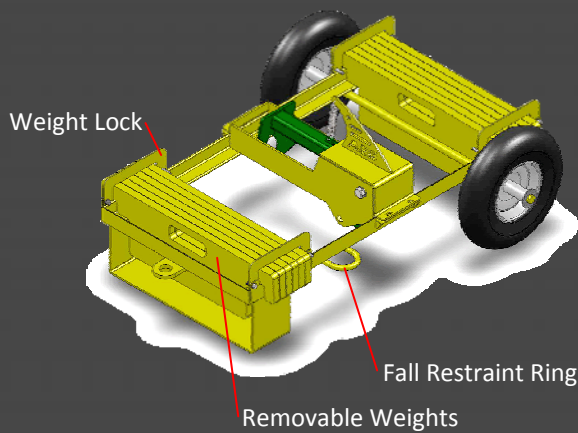

[WWW.RAPTORSAFETY.COM](http://WWW.RAPTORSAFETY.COM)

## IDEAL USES FOR THE STINGER:

- ROOF REPAIR AND WATER LEAKS
- LEADING EDGE MAINTENANCE
- GUTTER CLEANING
- HVAC INSTALLATION AND MAINTENANCE
- SKYLIGHT INSTALLATION AND MAINTENANCE
- SUPPORT FOR WINDOW WASHING CREWS
- CHRISTMAS LIGHT INSTALLATION AND MAINTENANCE
- LIGHTNING PROTECTION INSTALLATION AND MAINTENANCE
- SHORT WAVE RADIO ANTENNA INSTALLATION AND MAINTENANCE
- BIRD AND RODENT DIVERSION INSTALLATION AND MAINTENANCE
- EXTERIOR SECURITY CAMERA INSTALLATION AND MAINTENANCE
- WIRELESS NETWORK ANTENNA INSTALLATION AND MAINTENANCE

### DIMENSIONS:

LENGTH	51"
WIDTH	39"
HEIGHT	21.25"

### WEIGHT:

WORKING WEIGHT	726 Pounds (Working Weight)
FRAME	126 Pounds (With Engagement Box) 89 Pounds (Without Engagement Box)

REMOVABLE WEIGHTS 50 Pounds (12 per unit)

TIRES Solid Polyurethane 4.8 x 4.0 x 8

WARRANTY Manufacturers limited warranty covers any defect in workmanship or materials; One year from date of purchase

FALL PROTECTION STANDARDS 1926.502 (D) Fall Arrest Anchor

FALL ARREST CAPACITY 1 Worker (310lb)

FALL RESTRAINT CAPACITY 1 Worker (310lb)

## AES Raptor Stinger™

### Mobile Fall Protection System

Compliant with OSHA Regulation 1926.502 (D)

Allows one worker to be tied for fall arrest and one for fall restraint at the same time

Lightweight and portable

Easily moved and set up by one person

Easily fits into elevators

Easily fits into pickups

Easily fits through doorways

Flat Free Tires standard.

Engagement Claw Lock keeps the claw anchored if a fall occurs



Transport Dolly



Removable Weight 50 Pounds

**TOLL-FREE 1-888-990-2990**

**WWW.RAPTORSAFETY.COM**